

## Profilabmessungen der Ganzglas-Schiebeanlage

Obere Laufschiene 3-spurig

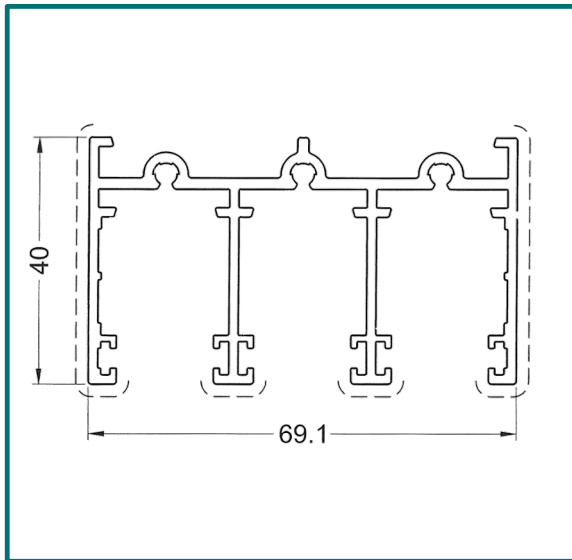

Untere Laufschiene 3-spurig

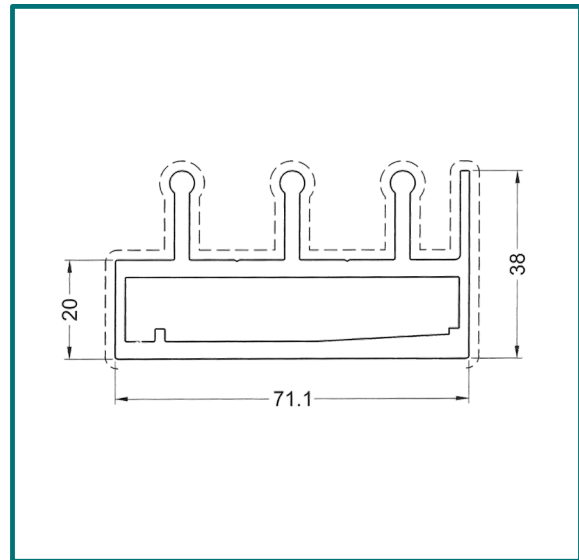

Obere Laufschiene 4-spurig

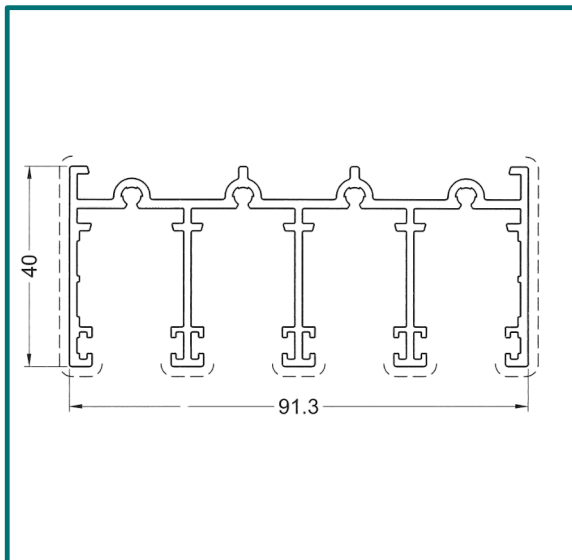

Untere Laufschiene 4-spurig

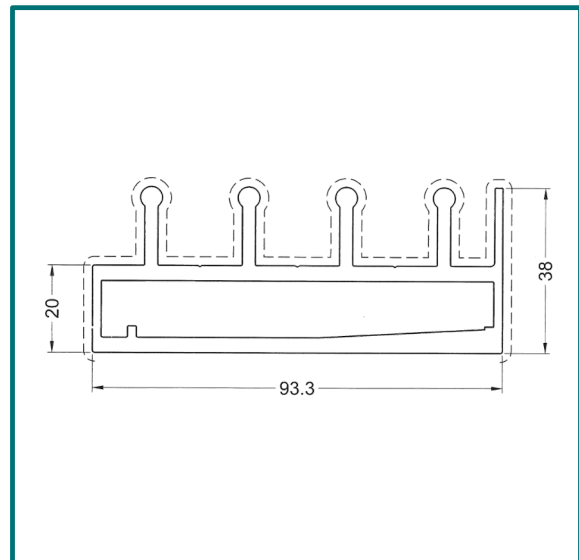

Obere Laufschiene 5-spurig

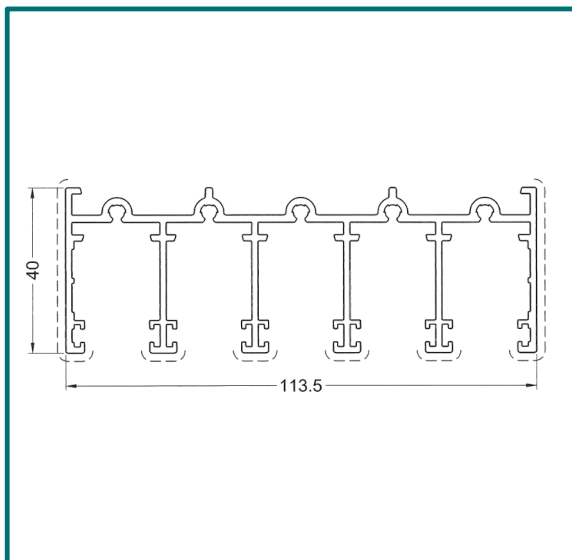

Untere Laufschiene 5-spurig

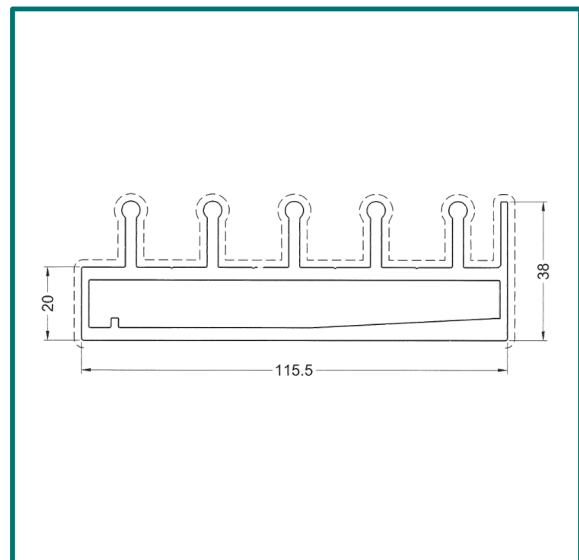

## Profilabmessungen der Ganzglas-Schiebeanlage

Obere Laufschiene 3-spurig mit Abdeckprofil

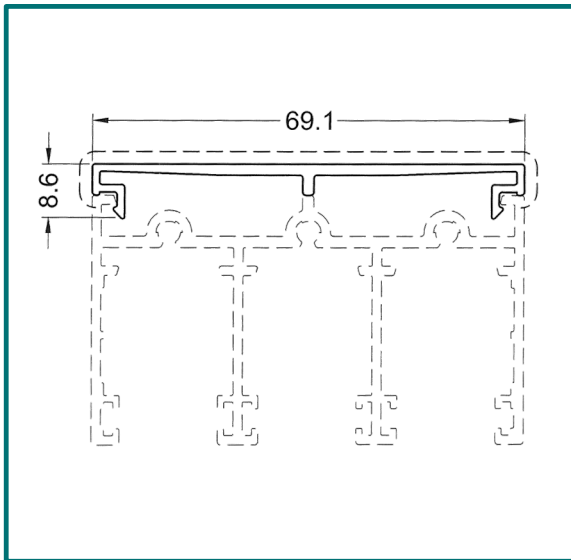

Obere Laufschiene 4-spurig mit Abdeckprofil

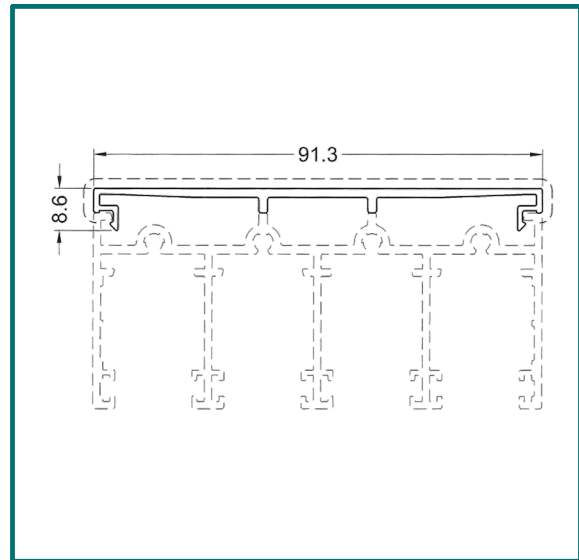

Obere Laufschiene 5-spurig mit Abdeckprofil

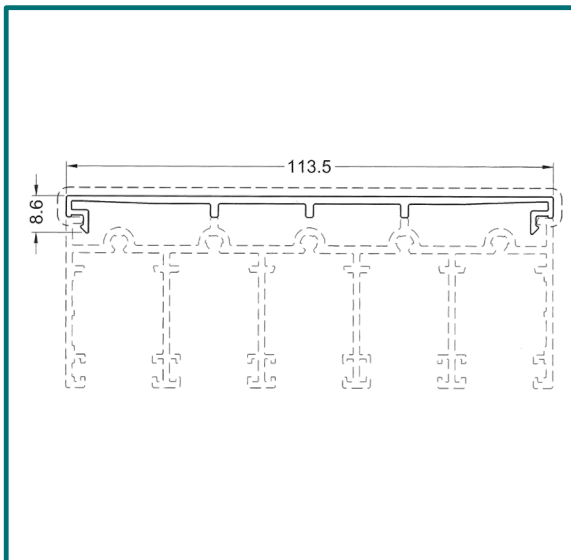

Seitlicher Rahmen 3-spurig

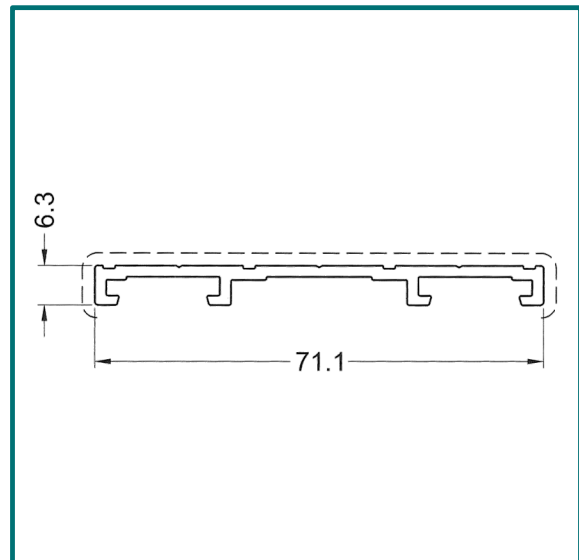

Seitlicher Rahmen 4-spurig

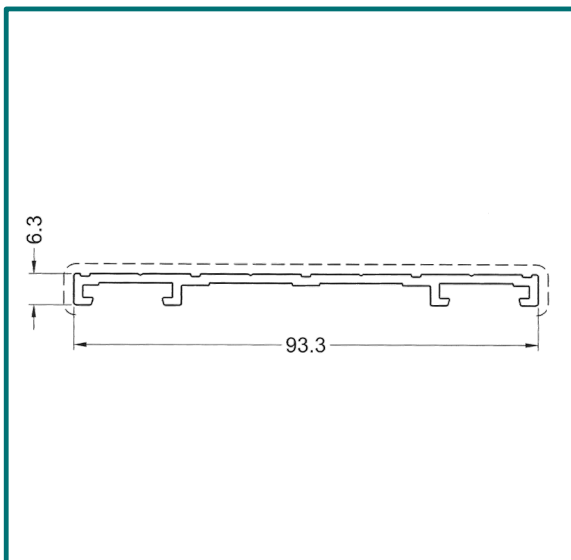

Seitlicher Rahmen 5-spurig

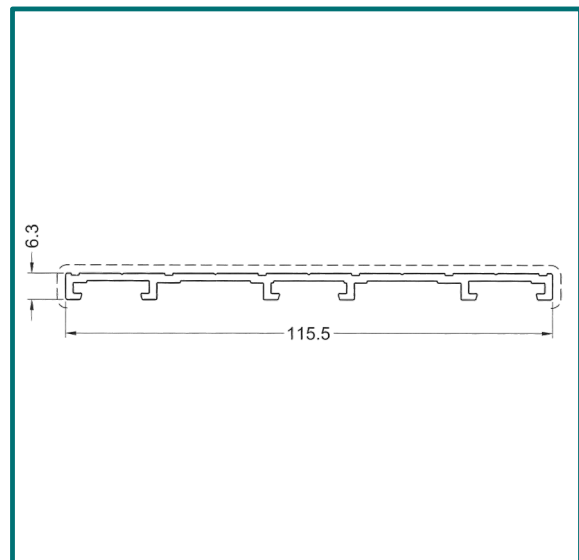

## Profilabmessungen der Ganzglas-Schiebeanlage

Flügel

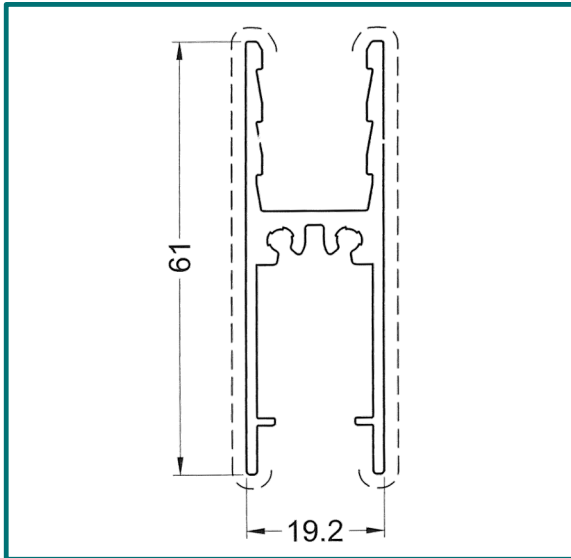

Bahnhof

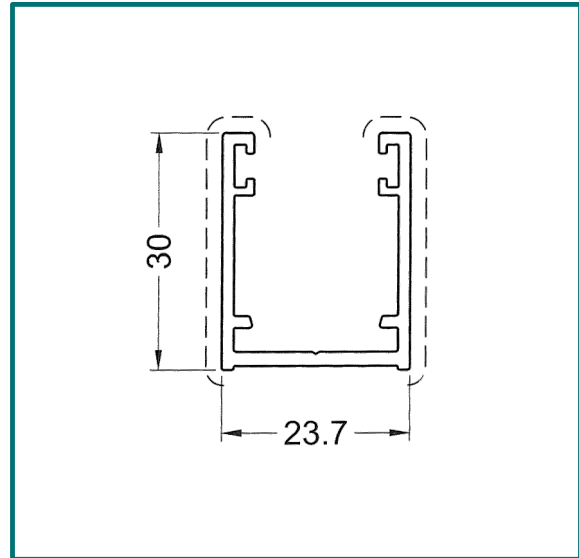

Staubdichtung

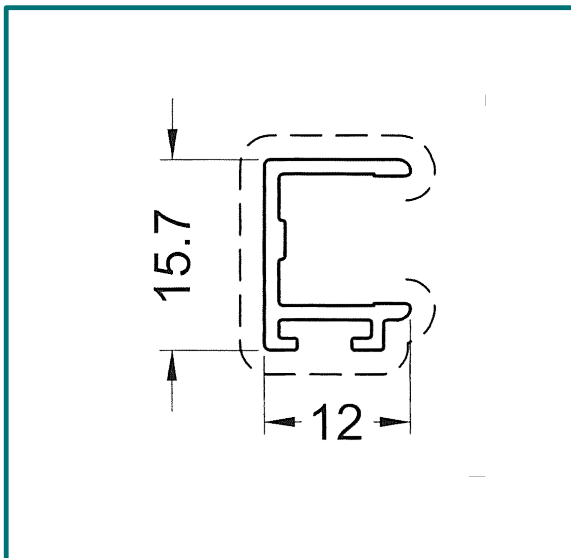

Laufschiene

